

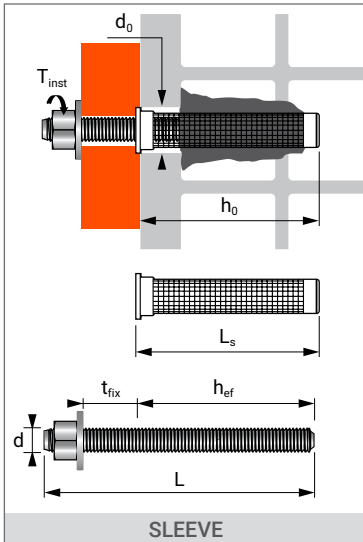

Epoxyacrylate resin for fixing in hollow masonry

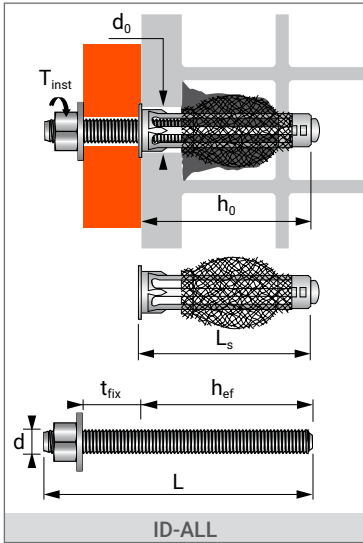

TECHNICAL DATA

RANGE	Minimum anchor depth (mm) h_{ef}	Drilling depth (mm) h_0	Drilling diameter (mm) d_0	Thread diameter (mm) d	Minimum stud length (mm) L	External diameter ID-ALL/SLEEVE (mm) d_{nom}	Total length ID-ALL/SLEEVE (mm) L_s	Tighten torque (Nm) T_{inst}
ID-ALL + stud M8	65	70	16	8	$76 + t_{fix}$	16	70	$3^{(1)}$
ID-ALL + stud M10	65	70	16	10	$78 + t_{fix}$	16	70	$3^{(1)}$
Sleeve Ø15 + stud M8	130	135	15	8	$138 + t_{fix}$	15	130	$3^{(1)}$
Sleeve Ø15 + stud M10	130	135	15	10	$140 + t_{fix}$	15	130	$3^{(1)}$
Sleeve Ø20 + stud M12	85	90	20	12	$98 + t_{fix}$	20	85	$3^{(1)}$
MULTI-MAX cartridge 410 ml*								060047
MULTI-MAX cartridge 280 ml*								060040

For sleeves and studs code numbers, see catalogue.

⁽¹⁾ 2Nm in clay masonry OPTIBRIC PV3+ and in hollow concrete block

* Shelf life : 18 months

SETTING TIME

TEMPERATURE	MAX. TIME FOR INSTALLATION	CURING TIME
-5°C ▶ 0°C	-	360 min.
0°C ▶ 5°C	18 min.	180 min.
5°C ▶ 10°C	12 min.	90 min.
10°C ▶ 20°C	6 min.	60 min.
20°C ▶ 30°C	4 min.	45 min.
30°C ▶ 40°C	2 min.	35 min.

CHARACTERISTIC & MINIMUM DISTANCES FOR SPACING, EDGE

SIZE	M8	M10	M12	M8/M10
SLEEVE	15X130	15X130	20X85	ID-ALL
HOLLOW CLAY BRICK (fb > 12 N/mm ²)	$C_{min} = C_{cr}$ [mm]	100	100	100
	$S_{min} = S_{cr}$ [mm]	200	200	200
HOLLOW CONCRETE BLOCK (fb > 4 N/mm ²)	$C_{min} = C_{cr}$ [mm]	100	100	100
	$S_{min} = S_{cr}$ [mm]	200	200	200

CHARACTERISTICS



APPLICATION

- Signs
- Scaffolding
- Electrical switchboards
- Radiators
- Air conditioning ducts
- Rail guard returns
- Blinds
- Climbing walls
- Metal scale
- Hand rails
- Pole and ducts
- Demountable partitions
- Kitchen furniture

INSTALLATION

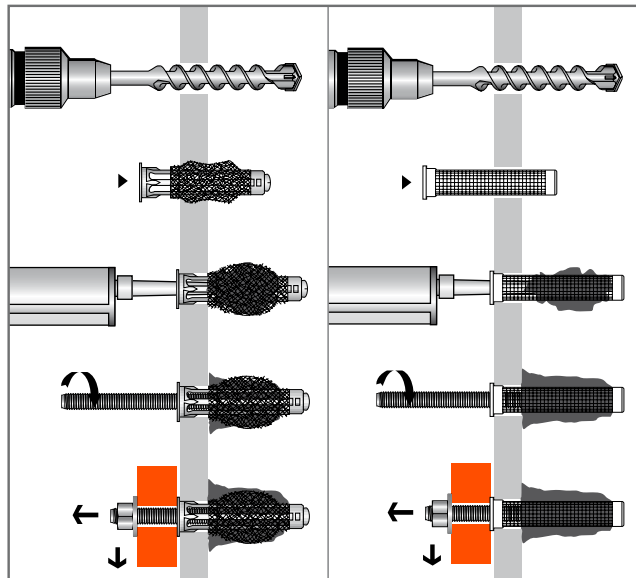



CHARACTERISTIC RESISTANCES [kN]

Characteristic resistances are shown as informative, and have to be used by application of safety factors.

TENSILE

MASONRIES

SIZE	ID-ALL		SLEEVE		
	M8	M10	Ø20X80 M12	Ø15X130 M8 M10	
Hollow concrete block B40 (fb ≥ 6,0 N/mm²)					
N _{Rk} [kN]	2,28		1,75	1,72	
Hollow clay brick Optibric PV 3+ (fb ≥ 9,0 N/mm²)					
N _{Rk} [kN]	1,72		2,84	1,72	
Hollow clay brick Porotherm GF R20 Th+ (fb ≥ 9,0 N/mm²)					
N _{Rk} [kN]	1,00		2,84	1,36	
Hollow clay brick Porotherm GF R37 Th+ (fb ≥ 9,0 N/mm²)					
N _{Rk} [kN]	1,36		1,00	2,28	
Calcium silicate masonries KSL-R (P) 240 (fb ≥ 9,0 N/mm²)					
N _{Rk} [kN]	1,72		4,00	3,44	

SHEAR

MASONRIES

SIZE	ID-ALL		SLEEVE		
	M8	M10	Ø20X80 M12	Ø15X130 M8 M10	
Hollow concrete block B40 (fb ≥ 6,0 N/mm²)					
V _{Rk} [kN]	2,84		2,28	3,44	
Hollow clay brick Optibric PV 3+ (fb ≥ 9,0 N/mm²)					
V _{Rk} [kN]	1,72		4,00	1,36	
Hollow clay brick Porotherm GF R20 Th+ (fb ≥ 9,0 N/mm²)					
V _{Rk} [kN]	4,56		3,44	4,00	
Hollow clay brick Porotherm GF R37 Th+ (fb ≥ 9,0 N/mm²)					
V _{Rk} [kN]	1,00		4,56	1,72	
Calcium silicate masonries KSL-R (P) 240 (fb ≥ 9,0 N/mm²)					
V _{Rk} [kN]	10,28	12,56	11,40	10,28	13,72

RECOMMENDED LOADS OF ONE ANCHOR WITHOUT INFLUENCE OF SPACING & CONCRETE EDGE [kN]

Recommended values are determined from performances given in the ETA, and are guaranteed for spacing ≥ S_{cr} and edge distance ≥ C_{cr}.

TENSILE

MASONRIES

SIZE	ID-ALL		SLEEVE		
	M8	M10	Ø20X80 M12	Ø15X130 M8 M10	
Hollow concrete block B40 (fb ≥ 6,0 N/mm²)					
N _{Rec} [kN]	0,57		0,43	0,43	
Hollow clay brick Optibric PV 3+ (fb ≥ 9,0 N/mm²)					
N _{Rec} [kN]	0,43		0,71	0,43	
Hollow clay brick Porotherm GF R20 Th+ (fb ≥ 9,0 N/mm²)					
N _{Rec} [kN]	0,25		0,71	0,34	
Hollow clay brick Porotherm GF R37 Th+ (fb ≥ 9,0 N/mm²)					
N _{Rec} [kN]	0,34		0,25	0,57	
Calcium silicate masonries KSL-R (P) 240 (fb ≥ 9,0 N/mm²)					
N _{Rec} [kN]	0,43		1,00	0,86	

γ_F = 1,4 ; γ_M = 2,4

SHEAR

MASONRIES

SIZE	ID-ALL		SLEEVE		
	M8	M10	Ø20X80 M12	Ø15X130 M8 M10	
Hollow concrete block B40 (fb ≥ 6,0 N/mm²)					
V _{Rec} [kN]	0,71		0,57	0,86	
Hollow clay brick Optibric PV 3+ (fb ≥ 9,0 N/mm²)					
V _{Rec} [kN]	0,43		1,00	0,34	
Hollow clay brick Porotherm GF R20 Th+ (fb ≥ 9,0 N/mm²)					
V _{Rec} [kN]	1,14		0,86	1,00	
Hollow clay brick Porotherm GF R37 Th+ (fb ≥ 9,0 N/mm²)					
V _{Rec} [kN]	0,25		1,14	0,43	
Calcium silicate masonries KSL-R (P) 240 (fb ≥ 9,0 N/mm²)					
V _{Rec} [kN]	2,57	3,14	2,85	2,57	3,43

γ_F = 1,4 ; γ_M = 2,4

Design resistances for static loads are determined from performances given in the ETA, and are guaranteed for spacing ≥ S_{cr} and edge distance ≥ C_{cr}.

For project with reduced spacing and edge distance, we recommend to use SPIT i-Expert software to design your project.



DESIGN RESISTANCE FOR STATIC LOADS IN MASONRIES [kN]

TENSILE

MASONRIES

SIZE	ID-ALL		SLEEVE		
	M8	M10	Ø20X80 M12	Ø15X130 M8 M10	
Hollow concrete block B40 (fb ≥ 6,0 N/mm²)					
N _{Rd} [kN]	0,76		0,57	0,57	
Hollow clay brick Optibric PV 3+ (fb ≥ 9,0 N/mm²)					
N _{Rd} [kN]	0,57		0,94	0,57	
Hollow clay brick Porotherm GF R20 Th+ (fb ≥ 9,0 N/mm²)					
N _{Rd} [kN]	0,33		0,94	0,45	
Hollow clay brick Porotherm GF R37 Th+ (fb ≥ 9,0 N/mm²)					
N _{Rd} [kN]	0,45		0,33	0,76	
Calcium silicate masonries KSL-R (P) 240 (fb ≥ 9,0 N/mm²)					
N _{Rd} [kN]	0,57		1,33	1,14	

SHEAR

MASONRIES

SIZE	ID-ALL		SLEEVE		
	M8	M10	Ø20X80 M12	Ø15X130 M8 M10	
Hollow concrete block B40 (fb ≥ 6,0 N/mm²)					
V _{Rd} [kN]	0,94		0,76	1,14	
Hollow clay brick Optibric PV 3+ (fb ≥ 9,0 N/mm²)					
V _{Rd} [kN]	0,57		1,33	0,45	
Hollow clay brick Porotherm GF R20 Th+ (fb ≥ 9,0 N/mm²)					
V _{Rd} [kN]	1,52		1,14	1,33	
Hollow clay brick Porotherm GF R37 Th+ (fb ≥ 9,0 N/mm²)					
V _{Rd} [kN]	0,33		1,52	0,57	
Calcium silicate masonries KSL-R (P) 240 (fb ≥ 9,0 N/mm²)					
V _{Rd} [kN]	3,42	4,18	3,79	3,42	4,56